

www.aquaflam.cz



Aquaflam Vario Wood Boiler Stove

A practical modern solution to your stoves heating needs





Aquaflam Vario

WOOD BOILER STOVES

you choose the...

DESIGN, COLOUR, POWER OUTPUT, REGULATION

4 DESIGN PRODUCT LINES

The Saporo, Kalmar, Lend and Barma represent the complete range of Aquaflam Vario wood stove design options.

SELECTION OF COLOUR OPTIONS

There are 5 colour options to choose from for the Saporo, Lend and Kalmar wood stoves - grey, cream, red and two luxurious colours - brown velvet and metallic cream. The Barma wood stove has a tiled exterior in Maple, Walnut and Bleached oak.

SELECTION OF POWER OUTPUT

The wood stove is supplied with a heat exchanger as standard. The customer has the option of choosing from two power outputs: 3 - 9kW and 5 - 11kW into water.

REGULATION

There are two types of control systems available for the wood stove. A manual option using a draw bar and an electronic option using a potentiometer with a safety heat sensor.

HOT WATER BOILER / HOT CONVECTION AIR VERSIONS

If you decide to heat without a heat exchanger, you have the option of very easily replacing it with a blocking plate (deflector), which when used makes it possible to operate the stove in a hot air convection mode.

TILE REPLACEMENT

Furthermore, on the Barma wood stove, it is possible to replace the tiles at any time.

The logo for Aquaflam Vario is embossed on a dark, metallic-looking surface. It features a square icon on the left containing a stylized 'Q' and 'V' symbol. To the right of the icon, the word 'AQUAFLAM' is written in a large, bold, sans-serif font, and the word 'VARIO' is written in a smaller, bold, sans-serif font directly below it.

AQUAFLAM
VARIO

A **new product** from **HS Flamingo**. A state-of-the-art wood boiler stove that meets the requirements of even the most demanding customers. **Highly effective** and environmentally friendly. **Secondary combustion** technology with an efficiency exceeding 80%. A unique solution providing a simple transition **from heating using water to heating with hot convection air**. Made from the best quality materials, using a technology that meets the strictest European norms. A **cooling loop**, that protects against overheating is included as standard. **Tertiary air supply** for perfect combustion and a continuous supply of air. There is, of course, an option to connect **outside air** to the stove. The optional integrated **electronic air supply regulation** automatically protects against overheating.

You can choose how you will operate your wood stove. Two heat exchanger power outputs and the option to operate the stove in full convection mode is Aquaflam VARIO !

modern blackened glass

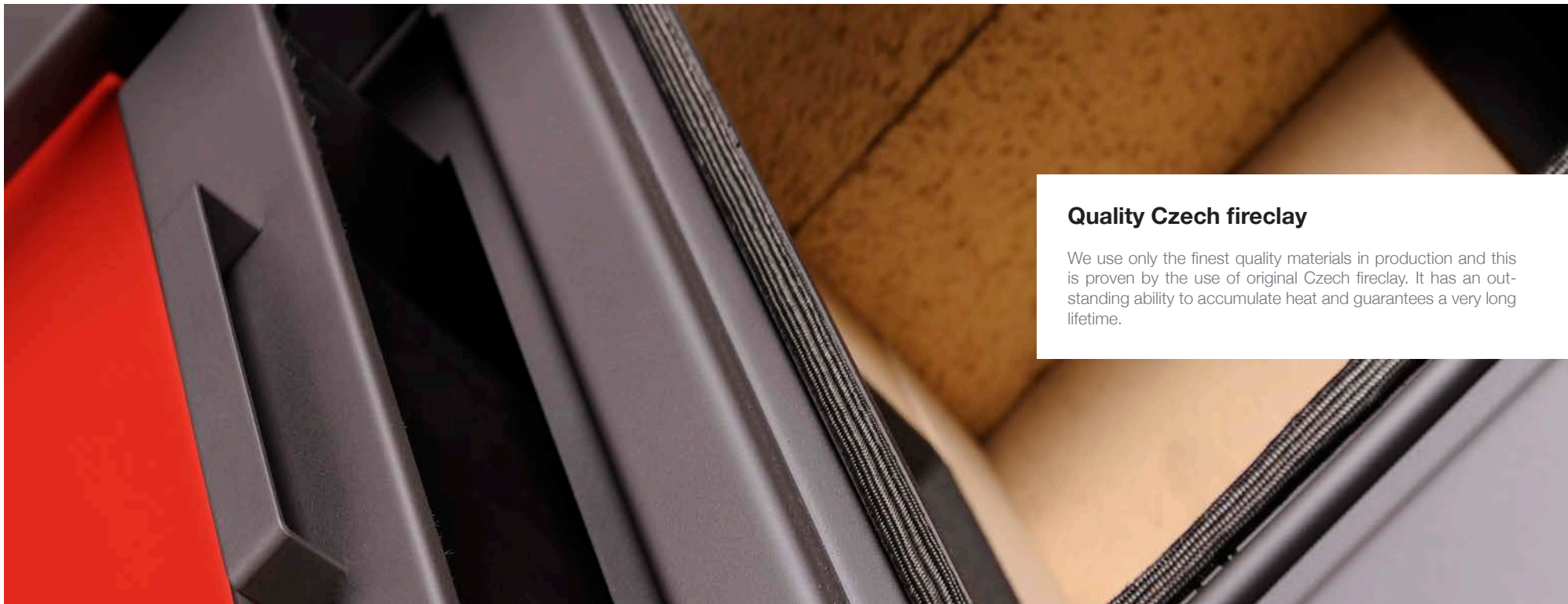

Quality Czech fireclay

We use only the finest quality materials in production and this is proven by the use of original Czech fireclay. It has an outstanding ability to accumulate heat and guarantees a very long lifetime.

when fire and water work together

The key feature of a modern wood stove is the ability to heat multiple rooms using radiators. AQUAFLAME VARIO wood stoves have a built-in heat exchanger, which ensures that heating water is heated quickly and effectively. Thanks to this, you can heat several rooms and even the entire house. At the same time, these stoves heat the room where they are located. Heat is transferred through the glass door and AQUAFLAM VARIO wood stoves also create so-called convective heat, which is produced by sucking in cold air and emitting it through the top air outlet. AQUAFLAM VARIO wood stoves ensure an even distribution of heat in the home and play the role of either the primary or secondary source of heat. This makes them a very much demanded product on the European market.



Gasket cord with a protective layer

A gasket cord that you do not need to change after each season. It really handles what no other can.



Reliable three-point locking system

Problem-free operation is important for us. The three-point locking system ensures the proper and long functioning locking of the firebox door.



Perfect combustion

Ensures an intelligent delivery of primary, secondary and tertiary air into the firebox.



Eko-Air-In outside air supply

An ideal connection is directly from the outside of the house. Aquafam VARIO wood stoves are equipped with an inlet adapter for this air delivery as standard.

Technical cross-section of the wood stove

AQUAFLAM VARIO

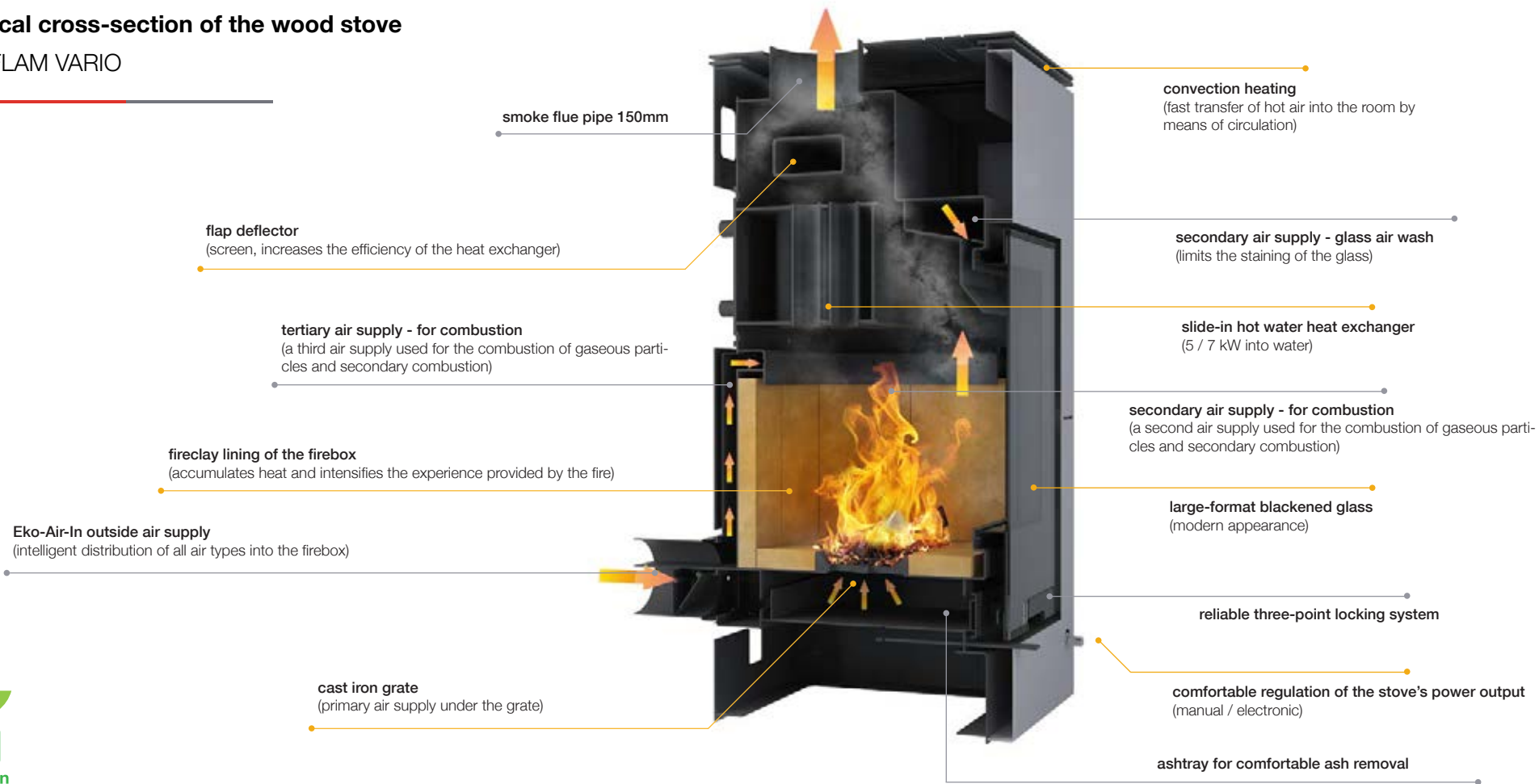

Eko-Air-In ensures a central air supply by sucking outside air into the rear part of the stove. The entire combustion process is controlled using only a single control element in the bottom right corner of the wood stove. The Eko-Air-In system also provides protection against the explosion of gaseous particles by continuously sucking in fresh air. This innovative element ensures a high efficiency, lowers fuel consumption by up to 40% and is particularly environmentally friendly. The amount of ash is minimal.

Aquaflam VARIO wood stoves meet the strictest European CE norms (EN 13240, BImSchV - Stufe 2, 15a B-VG, DINplus)

You select the power of the heat exchanger

HOT WATER BOILER / HOT CONVECTION AIR VERSIONS

All models and colour options are available also with the deflector (cover plate) enabling the stove to be operated without the need to be connected to the home's heating circuit.



hot water heat exchanger version
with a power output of 3-9 kW and 5-11 kW



convective version with a deflector
(can be purchased for all models)



wood stove

saporo



www.aquafiam.cz

brown - velvet

cream - metallic

red

grey



technical parameters

	5kW	7kW
Total power output range kW	7 - 15	
Output into water range kW	3 - 9	5 - 11
Stove efficiency %	80.47	80.19
Fuel consumption kg/hour	3.2	
Operating draft Pa	12 - 14	12 - 14
Exhaust gas outlet mm	150	
Log length cm	45	
Weight kg	182	185
CO emissions (at 13% O ₂) %	0.0996	0.0933
Average flue-gas temperature °C	255	245
Volume of the heat exchanger l	10.2	8.7
Maximum operating pressure bar	2,5	
Warranty	5 years	

- + Primary, secondary and tertiary air supply
- + Secondary - perfect combustion
- + Glass wash - glass is always clean
- + Option to connect air from the outside
- + Vertical hot water heat exchanger
- + Cooling loop
- + Selection of a regulation (manual/electronic)
- + Ashtray
- + Extra long life gasket cord

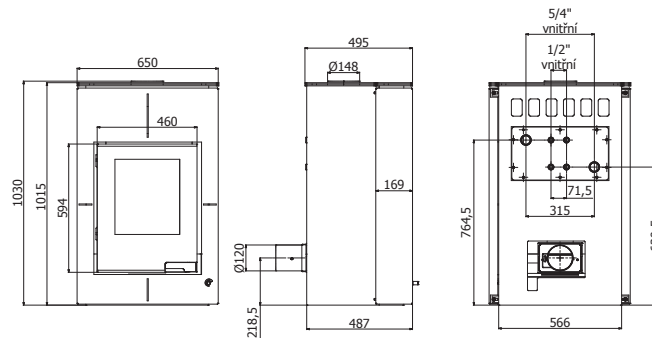
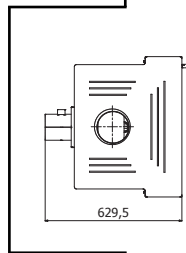

cream

produced by HS Flamingo s.r.o.











wood stove

kalmar



cream
cream - metallic
red
brown - velvet



technical parameters

	5kW	7kW
Total power output range kW	7 - 15	
Output into water range kW	3 - 9	5 - 11
Stove efficiency %	80.47	80.19
Fuel consumption kg/hour	3.2	
Operating draft Pa	12 - 14	12 - 14
Exhaust gas outlet mm	150	
Log length cm	45	
Weight kg	182	185
CO emissions (at 13% O ₂) %	0.0996	0.0933
Average flue-gas temperature °C	255	245
Volume of the heat exchanger l	10.2	8.7
Maximum operating pressure bar	2,5	
Warranty	5 years	

- + Primary, secondary and tertiary air supply
- + Secondary - perfect combustion
- + Glass wash - glass is always clean
- + Option to connect air from the outside
- + Vertical hot water heat exchanger
- + Cooling loop
- + Selection of a regulation (manual/electronic)
- + Ashtray
- + Extra long life gasket cord

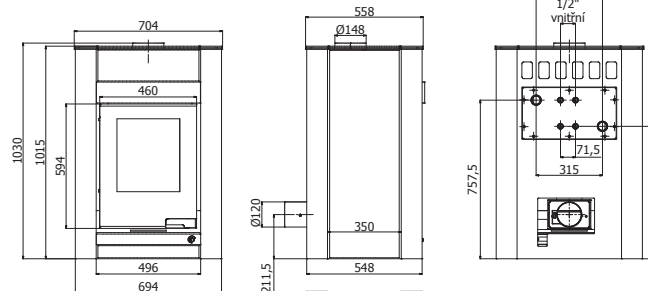
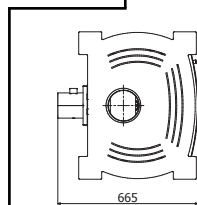

grey

produced by HS Flamingo s.r.o.











wood stove

lend



brown - velvet
cream
grey
cream - metallic



technical parameters

	5kW	7kW
Total power output range kW	7 - 15	
Output into water range kW	3 - 9	5 - 11
Stove efficiency %	80.47	80.19
Fuel consumption kg/hour	3.2	
Operating draft Pa	12 - 14	12 - 14
Exhaust gas outlet mm	150	
Log length cm	45	
Weight kg	182	185
CO emissions (at 13% O ₂) %	0.0996	0.0933
Average flue-gas temperature °C	255	245
Volume of the heat exchanger l	10.2	8.7
Maximum operating pressure bar	2,5	
Warranty	5 years	

- + Primary, secondary and tertiary air supply
- + Secondary - perfect combustion
- + Glass wash - glass is always clean
- + Option to connect air from the outside
- + Vertical hot water heat exchanger
- + Cooling loop
- + Selection of a regulation (manual/electronic)
- + Ashtray
- + Extra long life gasket cord

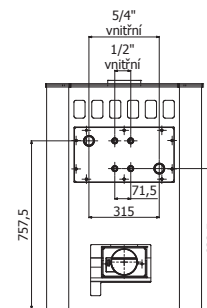
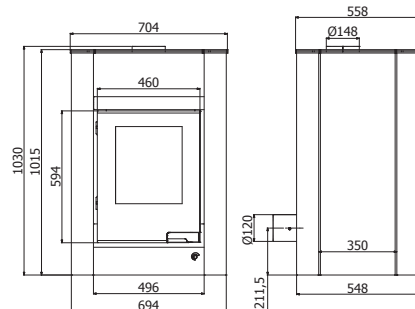
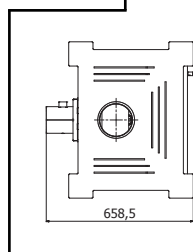

red

produced by HS Flamingo s.r.o.











wood stove

barma



www.aquaflam.cz

walnut tiles

whitened oak tiles



simple tile replacement



technical parameters 5kW 7kW

Total power output range kW	7 - 15	
Output into water range kW	3 - 9	5 - 11
Stove efficiency %	80.47	80.19
Fuel consumption kg/hour	3.2	
Operating draft Pa	12 - 14	12 - 14
Exhaust gas outlet mm	150	
Log length cm	45	
Weight kg	182	185
CO emissions (at 13% O ₂) %	0.0996	0.0933
Average flue-gas temperature °C	255	245
Volume of the heat exchanger l	10.2	8.7
Maximum operating pressure bar	2,5	
Warranty	5 years	

- + Primary, secondary and tertiary air supply
- + Secondary - perfect combustion
- + Glass wash - glass is always clean
- + Option to connect air from the outside
- + Vertical hot water heat exchanger
- + Cooling loop
- + Selection of a regulation (manual/electronic)
- + Ashtray
- + Extra long life gasket cord

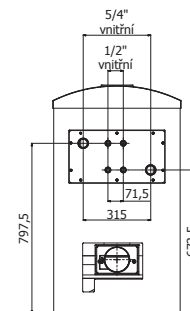
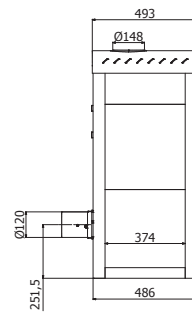
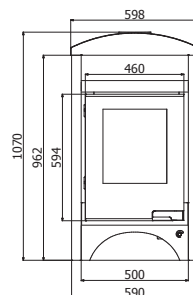
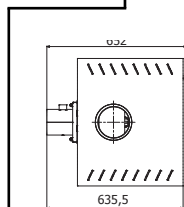

maple tiles

produced by HS Flamingo s.r.o.







Visualisation of a typical wood stove installation

AQUAFLAM VARIO

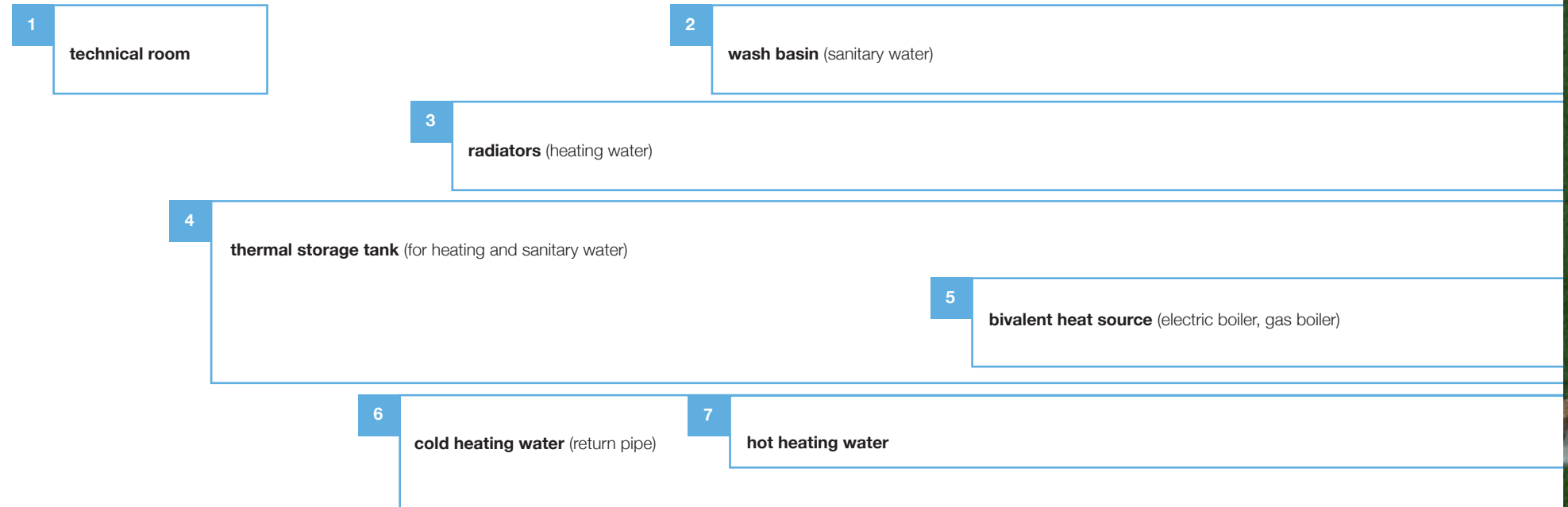

Today, a hot water heating system is becoming an increasingly popular heating method by which a fireplace insert or wood stove can be used for heating the entire house. An Aquaflam Vario wood stove will provide you with effective heating of the entire house while unlocking the magic of a flickering flame directly in your living room.

At the present time we have many satisfied customers who speak very highly of this system. Thanks to this bird's eye view, you have a basic overview and information about how a hot water heating system could work in your home. Furthermore, you can clarify exactly what you need to purchase for everything to work properly. If this house model does not match your needs, please do not hesitate to contact us and we will advise you about how to proceed in your particular case.



1

4

5

2

3

3

6

7

Safety of operation

Overheating protection

In the event that the temperature rises and there is a risk of overheating, the pressure inside the heat exchanger will start increasing rapidly. In order to prevent damaging it, the wood stove must have protection against overheating. We can prevent overheating using a safety valve, a cooling loop and a backup power source or a water drain leading to sewage lines and subsequent refilling from the mains water supply. However, if the refilling of water is reliant on electricity, we recommend the purchase of a backup power source (UPS).

Protection against the explosion of gasses

When the damper is in the closed position, the tertiary air supply is not completely shut off. So, even if it is fully closed, a certain amount of air flows into the chamber. This safety feature protects the user against the explosion of accumulated gasses.

Protective measures preventing high temperatures in the heat exchanger.

As soon as the electronic damper sensor registers an increased temperature in the heat exchanger, the damper shuts automatically and so reduces the amount of combustion air to a minimum. (Available only on models with the basic electronic regulation)

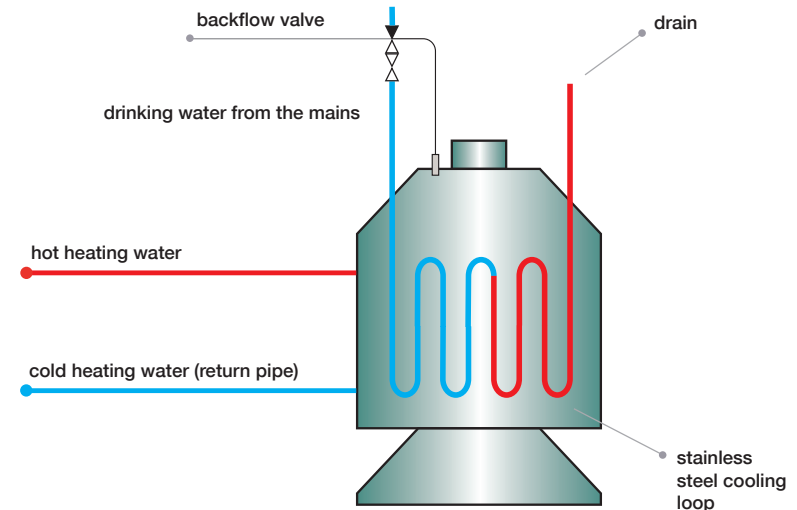

The basic AQUAFLAM VARIO wood stove models are equipped with a cooling loop, which when connected to a thermostatic valve protects the heat exchanger against overheating.

Connection - technical area

A professional installation is very important for the system to function properly and to ensure its long lifetime. The heating system must be equipped with the prescribed elements, which will ensure safe operation. The entire system must be separated into a short and long circuit, so that the lifetime of the heat exchanger is not threatened. If the temperature of the water in system is too low, corrosion results and the lifetime of the system is reduced. Furthermore, it is necessary to secure the system against overheating. All the basic versions of the Aquaflam VARIO wood stoves have this safety element. It consists of a cooling loop, which thanks to a thermostatic valve, cools the water in the heat exchanger.

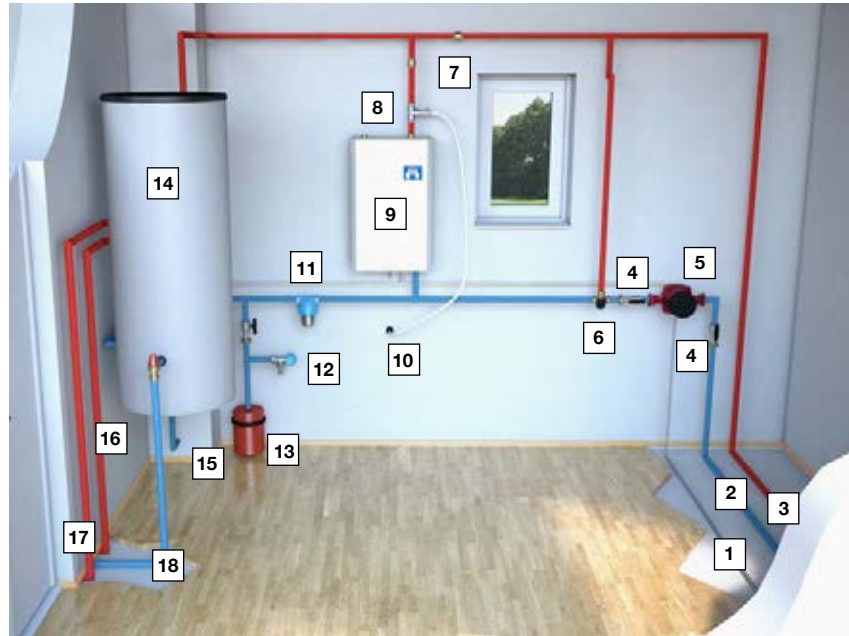

- 1** Communications cable (for the thermostat)
- 2** Cold heating water (return pipe) cools the water in the heat exchanger if necessary.
- 3** Hot heating water
- 4** Ball valve
- 5** Pump (recommended with a backup el. power source)

- 6** Thermostatic three way valve
- 7** Backflow valve
- 8** Safety valve
- 9** Bivalent heat source (electric boiler, gas boiler)
- 10** Drain for safety valve
- 11** Filter box

- 13** Expansion vessel
- 14** Thermal storage tank (for heating and sanitary water)
- 15** Supply of drinking water from the water mains
- 16** Warm sanitary water (wash basin)
- 17** Hot heating water (radiators)
- 18** Cool heating water from the radiators

Connections of the hot water heat exchanger

AQUAFLAM VARIO

Selecting a regulation for your AQUAFLAM VARIO

We are professionals in our field and so we can give you the personal attention that is required to find the right solution for your heating needs. We are always here for you to help with answering any questions about connections or operation of the Aquaflam VARIO wood stove.

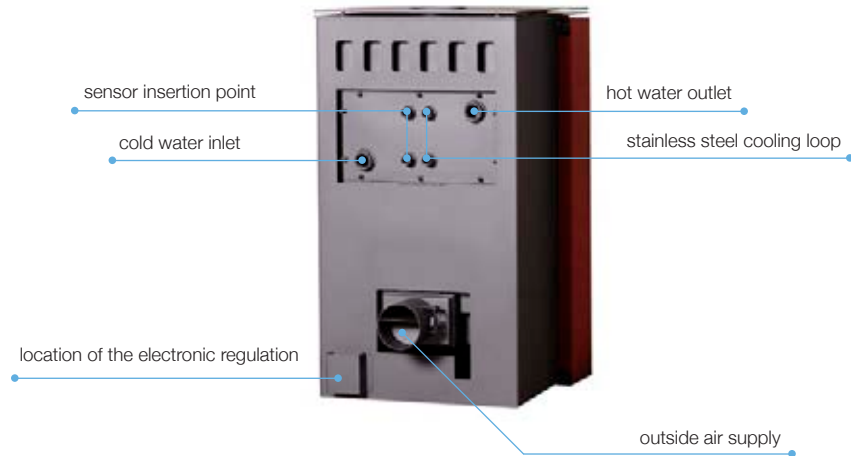

Selecting a regulation for your wood stove

AQUAFLAM VARIO

You can select the type of regulation for every model. You can choose from a classic manual style as well as an electronic regulation with an overheating protection sensor.

manual regulation

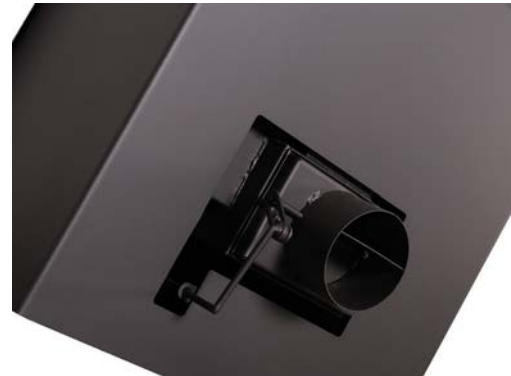

electronic regulation



complete product range at www.aquaflam.cz



vendor :

HS Flamingo s.r.o., třída Osvobození 65, CZ - 550 01 Broumov, Czech republic
tel.: +420 491 422 647, fax: +420 491 521 140
email: info@hsflamingo.cz, www.hsflamingo.cz

Contact for customers in Slovakia
tel.: 041/4214558 | e-mail: info@hsflamingo.sk